

MOEN® 摩恩®

智能坐便器 新月系列 安装说明书

Intelligent Toilet CRESCENT Series INSTALLATION INSTRUCTIONS

如需安装支持、配件替换，或遇配件丢失等情况，请联系本公司。

对于中国大陆以外的市场，请咨询当地经销商。

(中国大陆) 400-630-8866

(中国大陆) www.moen.cn

(中国大陆以外) www.moen.com.hk

For installation support, replacement parts, or missing items, please contact us.

For consumers in markets outside the Chinese mainland, please consult the local dealer.

(Chinese Mainland) 400-630-8866

(Chinese Mainland) www.moen.cn

(Outside Chinese Mainland) www.moen.com.hk



图片仅供参考
(款式因型号而异)

Image is for reference only
(Style varies by model)

记录购买的型号：

(保存安装说明书以备将来参考)

Record Purchased Model Number:
(Save instruction sheet for future reference)

推荐工具

为了安全和让安装和替换变得容易，本公司建议您使用以下工具：

HELPFUL TOOLS

For safety and ease of installation and replacement, we recommend the use of the following tools:

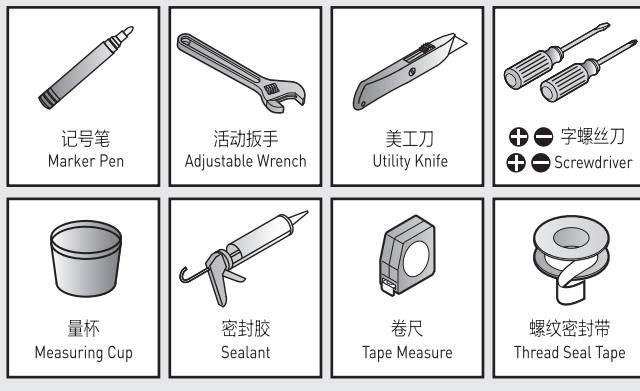

功能表 Function Table

功能分类 Functional Classification	型号 Model	SW1381C/D	SW1382C/D	SW1383C/D	SW1384C/D	SW1385C/D	
		深空灰 Black	石纹 Stone	白橡木 White oak	语音交互版 深空灰 w/voice control Black	语音交互版 白橡木 w/voice control White oak	
冲水类 Washing	虹吸冲水 Siphon Flush	●	●	●	●	●	
	易洁釉面 Easy-Clean Glaze	●	●	●	●	●	
	预润净瓷 Pre-flush	●	●	●	●	●	
	男士小便冲水 Flush for Male Urination	●	●	●	●	●	
	脚触冲水 Foot-Touch Flush	●	●	●	●	●	
	遥控冲水 Remote Control Flush	●	●	●	●	●	
	离座冲水 Automatic Flush	●	●	●	●	●	
	烘干冲水 Wind Drying with Flush	●	●	●	●	●	
	侧边键冲水 Side Button Flush	●	●	●	●	●	
	低压冲水 Low-Pressure Flush	●	●	●	●	●	
	停电冲水 Emergency Flush	●	●	●	●	●	
	电解水 Water Electrolysis	●	●	●	●	●	
清洗类 Cleaning	前置过滤(不锈钢网) Pre-filter with SUS Screen	●	●	●	●	●	
	清洗水过滤(PP棉) Water Purification with PP	●	●	●	●	●	
	臀洗 Rear Wash	●	●	●	●	●	
	妇洗 Front Wash	●	●	●	●	●	
	一键清洗 One-touch Wash	●	●	●	●	●	
	往复清洗 Moving Wash	●	●	●	●	●	
	宽幅清洗 Wide Range Wash	●	●	●	●	●	
	气泡清洗 Air Bubble Wash	●	●	●	●	●	
	脉冲清洗 Massage	●	●	●	●	●	
	冷热按摩 Hot and Cold Massage	●	●	●	●	●	
	水压调节 Water Pressure Adjustment	●	●	●	●	●	
	水温调节 Water Temperature Adjustment	●	●	●	●	●	
	喷嘴位置调节 Nozzle Position Adjustment	●	●	●	●	●	
	抗菌喷枪 Antimicrobial Nozzle	●	●	●	●	●	
	喷嘴自洁 Nozzle Self Cleaning	●	●	●	●	●	
	紫外线杀菌水 Water UV Sterilization	●	●	●	●	●	
	喷枪紫外线杀菌 Nozzle UV Sterilization	●	●	●	●	●	
	即热恒温 Instant Heating	●	●	●	●	●	
	灯光类 Lighting	LED夜灯 Night Light	●	●	●	●	●
		智能夜灯 Smart Night Light	●	●	●	●	●
舒适便捷类 Comfort and Convenience	座圈加热 Seat Heating	●	●	●	●	●	
	抗菌座圈 Antimicrobial Seat	●	●	●	●	●	
	暖风烘干 Wind Drying	●	●	●	●	●	
	快速烘干 Flash Drying	●	●	●	●	●	
	自动除臭 Automatic Deodorization	●	●	●	●	●	
	可拆卸喷嘴 Replaceable Nozzle	●	●	●	●	●	
	喷嘴保养 Nozzle Maintenance	●	●	●	●	●	
	舒适座圈 Comfortable Seat	●	●	●	●	●	
	座盖缓降 Soft-Close Cover	●	●	●	●	●	
	座圈缓降 Soft-Close Seat	●	●	●	●	●	
	便捷拆卸 Easy Disassembly	●	●	●	●	●	
	来电自启 Auto-start	●	●	●	●	●	
	智能节电 Smart Energy Saving	●	●	●	●	●	
	休眠模式 Automatic Power Off	●	●	●	●	●	
	个性设置 Individual Setting	●	●	●	●	●	
控制类 Controlling	遥控控制 Remote Control	●	●	●	●	●	
	旋钮控制 Turning Knob	●	●	●	●	●	
	电源开/关控制 Power Button	●	●	●	●	●	
	侧边停止按键 Side Stop Button	●	●	●	●	●	
	座圈感应 Sitting Sensor	●	●	●	●	●	
	座温调节 Seat Temperature Adjustment	●	●	●	●	●	
	风速调节 Wind Drying Adjustment	●	●	●	●	●	
	风速调节 Wind Speed Adjustment	●	●	●	●	●	
	感应翻盖 Automatic Flipping	●	●	●	●	●	
	手势翻盖 Gesture Flipping for Lid	●	●	●	●	●	
	手势翻圈 Gesture Flipping for Seat	●	●	●	●	●	
	脚触翻圈 Foot-touch Flipping for Seat	●	●	●	●	●	
	脚触翻盖 Foot-touch Flipping for Lid	●	●	●	●	●	
	语音控制 Voice Control	—	—	—	●	●	
	安全类 Safety	空气隔离 Air Isolation	●	●	●	●	●
防止逆流 Anti-counterflow		●	●	●	●	●	
安全保护 Safety Protection		●	●	●	●	●	

备注: ● 代表产品有此功能, — 代表产品无此功能。 Note: ● Indicates that the product has this function. — This function is not available for the product.

产品整体图 Product Overview

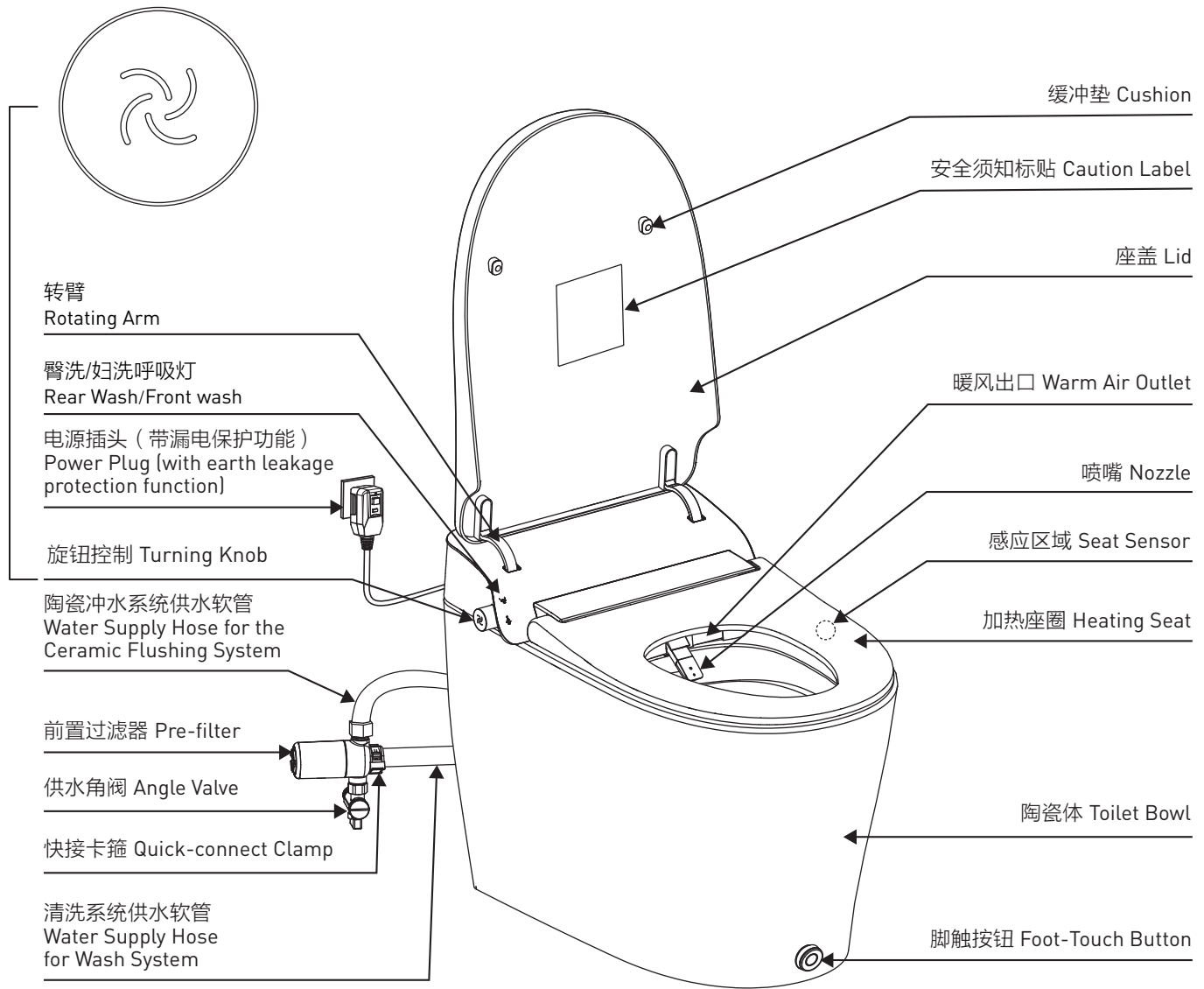

物品清单 Packing List

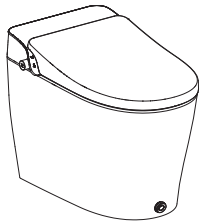

1 智能坐便器
Smart Toilet

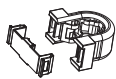

1 快接卡箍(含卡圈、锁盖)
Quick-connect Clamp
(With Snap Ring, Lock Cover)

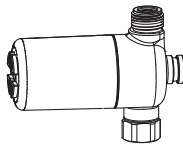

1 前置过滤器
Pre-filter

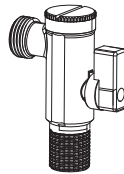

1 角阀
Angle Valve

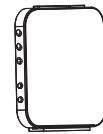

1 遥控器组件(含支架1个、数据线1根)
Remote control Assembly
(Including Holder×1, Data Cable×1)

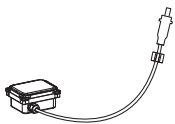

1 停电冲水电池盒组件
(含电池1块)
Battery Box Assembly For
Emergency Flushing
(Including Battery×1)

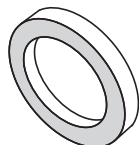

1 法兰密封圈
Flange with Wax Ring



2 可拆卸喷头(赠送2个)
Replaceable Nozzles
(2 For Free)

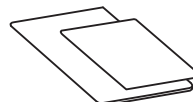

1 安装说明书、有害物质清单
Installation Instructions,
Hazardous Substance List

※请确认包装内物品是否完整，如有缺失，请及时与我们的客户中心取得联系。

※以上物品图片仅供参考，以实物为准。

※Please confirm whether the contents of the package are complete. If there is any missing, please contact our customer center in time.

※Image is for reference only, style varies by model.

产品尺寸 Dimensions

本公司保留随时变更图中标示尺寸的权利，无需另行通知。

The company reserves the right to change the dimensions on the drawing without prior notice.

完工墙面
The finished wall

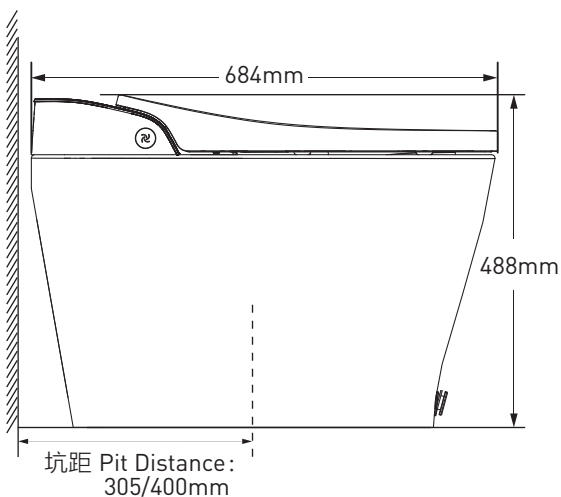

侧面图 Side View

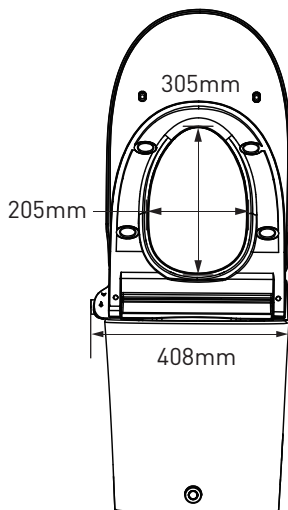

正视图 Front View

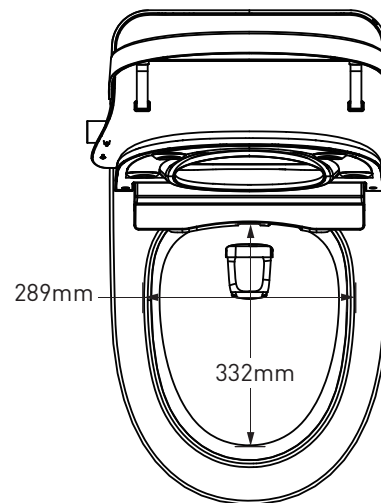



俯视图 Top View

产品安装 Product Installation

一. 安装前注意事项

以下注意事项均与安全密切相关，请务必遵守，否则可能根据不同情况造成不同程度的严重后果。

 **警告：** 如果无视警告而误操作时，有可能造成人员伤亡。

 **当心：** 如果无视当心而误操作时，有可能造成人身伤害或财产损失。

注意： 如无视注意而安装，有可能导致设备损坏或财产损失。

Precautions before Installation

The following precautions are closely related to safety and must be strictly observed. Failure to do so may result in various serious consequences depending on the specific situation.

 **WARNING:** If you ignore this warning and mis-operate, it may cause casualties.

 **CAUTION:** If you ignore this mark and mis-operate, it may cause personal injury or property damage.

NOTICE: If you ignore this notice, it may cause equipment damage or property damage.

 警告 WARNING	<p>请使用符合规格的电源插座（额定电压：交流220V ± 10%，额定电流：≥ 10A）。否则会引起插座发热并引发火灾。 Please use a socket that meets the specifications (Rated voltage: AC 220V±10%, Rated current: ≥10A). Failure to do so may cause the socket to overheat and result in a fire.</p>
	<p>请确认是否进行了接地处理。未接地的产品发生故障或漏电时可能会导致触电。 Ensure that the ground connection of the product is complete. Malfunction or leakage of ungrounded products may result in electric shock.</p>
	<p>危险! 存在触电危险，在操作前应切断电源。 Danger! There is a risk of electric shock. Cut off the power before operation.</p>
	<p>谨慎! 产品安装前，请关闭水源的总角阀，以免漏水导致财物损失。 Be careful! Before installing the product, close the main of the water source to avoid water leakage and property loss.</p>
	<p>谨慎! 存在有害气体的危险。如果坐便器不能立即安装，可在地面排污口上临时遮盖一块旧布。 Be careful! Danger of harmful gases. If the toilet cannot be installed immediately, temporarily cover the drainage outlet on the floor with a cloth.</p>
 当心 CAUTION	<p>连接进水管前，请先彻底冲洗供水管以清除管道中的杂质；使用市政自来水或可供饮用水作为接入水源。请勿使用海水、再生水等，以免引起皮肤不适或设备故障。 Before connecting the inlet pipe, rinse the water supply pipe thoroughly to remove impurities. To avoid skin irritation or equipment failure, use only municipal tap water or potable water as the water source for the device. Do not use other water sources such as seawater, reclaimed water, etc.</p>
	<p>遵守所有的本地管道安装和电气规程，电源和水管应采用墙式安装方式。 Observe all local plumbing and electrical regulations. Power and water pipes should be wall-mounted.</p>
	<p>安装在浴室内的插座位置距离浴缸或淋浴喷头应至少为1.0米，且插座应带有防水和防溅功能。 The electrical socket installed inside the bathroom should be positioned at least 1.0 meter away from the bathtub or showerhead, and it must be equipped with waterproof and splash-proof features.</p>
注意 NOTICE	<p>仔细检查坐便器有无损坏。 Check carefully whether the toilet is damaged.</p>

4

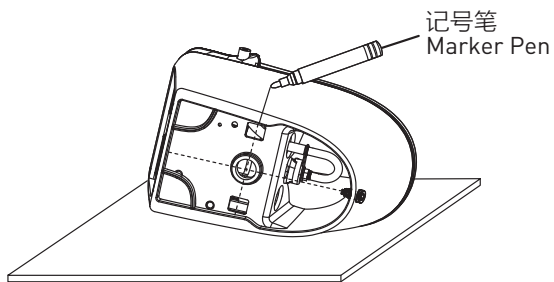

1. 将坐便器侧翻放置在柔软的地方。
2. 以陶瓷排污口为中心，按上图所示方式在陶瓷体侧面划线做标记。

1. Place the toilet on its side on a soft surface.
2. With the drain outlet as the center, mark lines on the side of the ceramic body as shown in the figure above.

5

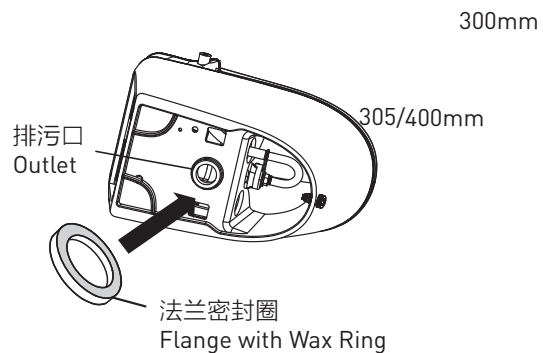

将法兰密封圈安装在陶瓷底部排污口上，注意连接紧密。

Install the Flange with Wax Ring on the drain outlet at the bottom of the ceramic, paying attention to the tight connection.

6

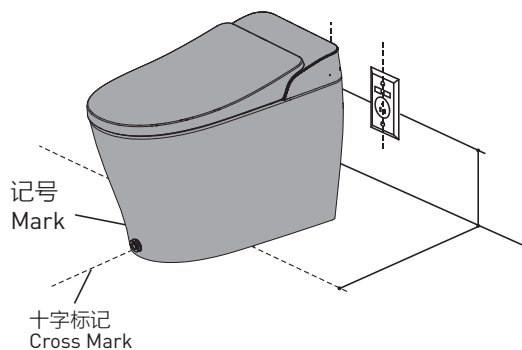

1. 抬起坐便器，将陶瓷体上的记号对准地面十字标记，将坐便器慢慢放到地面上调整使两者标记重合。
2. 将坐便器向下按压，使法兰密封圈充分接触地面，与地面连接紧密。
注意：在标记重合后切勿移动或左右摇晃坐便器，否则密封性可能遭到破坏，从而导致漏水。

1. Lift the toilet, align the mark on the ceramic body with the cross mark on the ground and slowly place the toilet on the ground adjusting so that the two marks coincide.
2. Push the toilet downward so that the Flange with Wax Ring fully touches the ground and attaches tightly to the ground.
Notice: Do not move or shake the toilet from side to side after aligning the marks, as this may damage the sealing and cause water leakage.

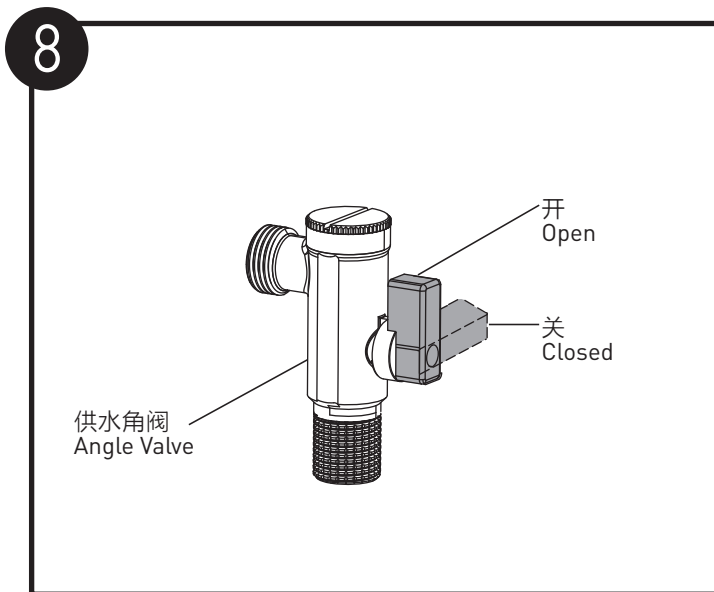
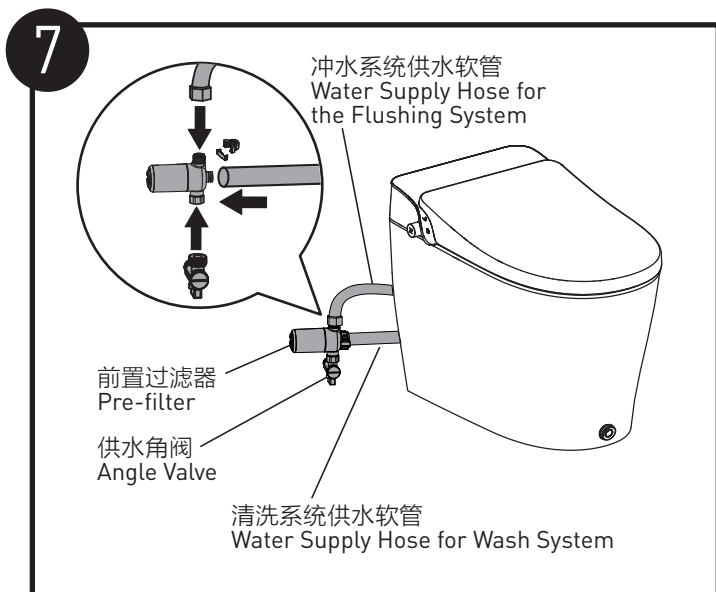

1. 用扳手将前置过滤器连接供水角阀和冲水系统供水软管。
2. 将清洗系统供水软管用力插入到前置过滤器出水口。将卡圈卡住此连接处，用力按压卡圈使卡圈自动卡死，盖上锁盖。

注意:

- 推荐扭力: 7N·m, 最大扭力不能超过18N·m。
- 当发现清洗强度减弱时, 请及时更换滤芯: 先关闭供水角阀, 再将旧滤芯逆时针旋出去丢弃到垃圾桶, 更换新的滤芯并顺时针旋入拧紧到位。
- 滤芯可以单独购买。

1. Attach the Pre-Filter to the Angle Valve and Water Supply Hose for the Flushing System by wrench.
2. Insert the Water Water Supply Hose for Washing System into the water outlet of Pre-Filter. Touch the retainer ring to lock it in place, until it automatically engages the joint firmly, and put down the Lock Lid.

Notice:

- Recommended torque: 7N·m, maximum torque should not exceed 18N·m.
- When the wash strength is found to be weakened, please replace the filter element in time. First, close the angle valve for water supply, then unscrew the old filter element counterclockwise and discard it into the trash. Replace with the new filter element and screw it clockwise and tighten it into place.
- The filter element can be purchased separately.

将角阀开到最大, 确认各连接部位没有漏水。如有漏水, 检查螺母是否拧紧或按步骤7重新操作。

Turn the Angle Valve to its maximum. Make sure there is no leakage at the link. If the water leaks, check that the nut is tight or repeat step 7.

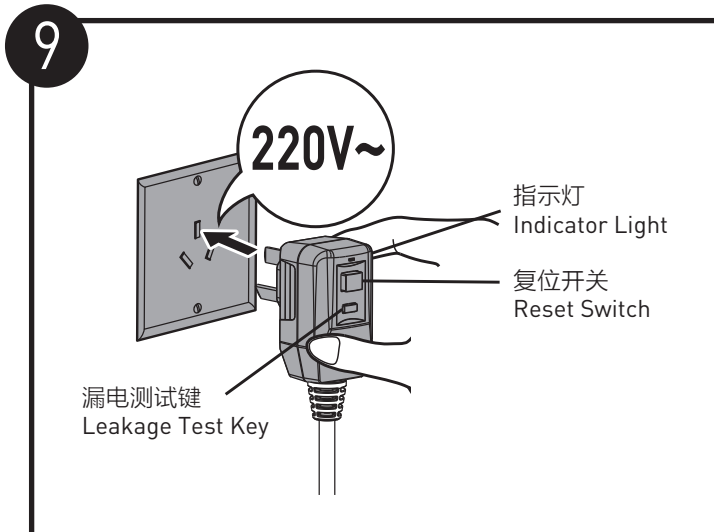

1. 确认插座的接地端口是否有效接地。
2. 电源插头插入AC 220V的插座内, 确认是否接通电源。
3. 确认插头指示灯是否亮起, 如指示灯变暗, 请试按复位开关。
4. 产品指示灯点亮, 确认坐便器处于开机状态。

1. Verify that the grounding port of the socket is effectively grounded.
2. Plug the power plug into the socket of AC 220V, make sure the power is switched on.
3. Confirm whether the plug Indicator light is lit-up. If the indicator light turns dark, press the Reset Switch.
4. Confirm that the toilet is powered on when the indicator light is on.

10



1. 测试以下功能是否正常工作：
臀洗和妇洗（包括水压调节、喷嘴位置调节）、烘干、水温调节、座温调节以及喷嘴清洗。
2. 测试臀洗/妇洗操作如下：
 - a. 用手贴住座圈感应区域以启动座圈传感器；
 - b. 逆时针旋转旋钮或按下遥控器上的“臀洗”按键；
 - c. 用手或挡板遮挡清洗器前端出水口，确认是否有柱状水流喷出。

1. To test whether the following functions work properly:
The Rear Wash and Front Wash (Including Water Pressure adjustment, Nozzle Position adjustment), Drying/Wind Temperature, Water Temperature and Seat Temperature adjustment, Nozzle Clean.
2. To test Rear Wash/Front Wash operation as follows:
 - a. To activate the seat sensor, place your hand on the designated area.
 - b. Counterclockwise the knob or press the  button on the remote control.
 - c. Use your hand or a shield to cover the water outlet at the front end of the washer, and check if there is a columnar water jet being sprayed out.

11

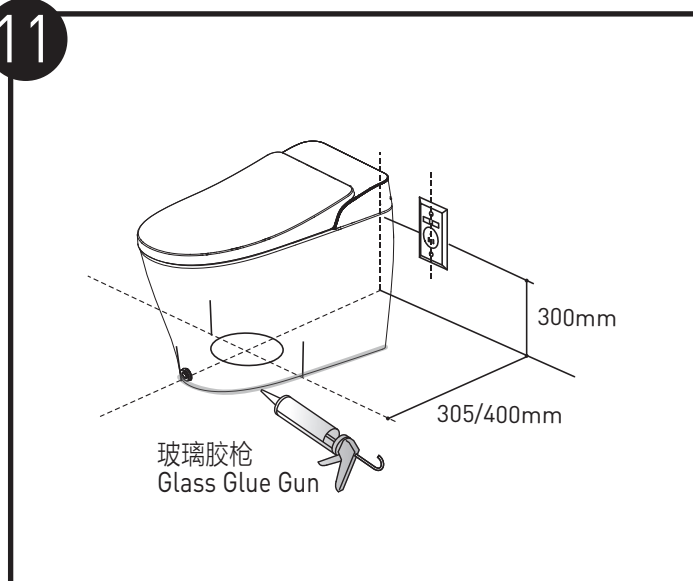

1. 在产品功能都测试完毕后，对地面不平部分填入填充物，使陶瓷不再摇晃。
2. 清洗陶瓷与地面接触部分，保持接触部分干燥。
3. 使用胶枪沿着陶瓷底部打上密封胶。

注意：

- 在产品调整时注意请小幅度轻轻调整，切不可调整幅度过大。
- 打上密封胶后，请于48小时后再使用。

1. After testing the product functions, fill any uneven ground with filler to stabilize the Ceramic.
2. Clean the Ceramic-ground contacts and keep them dry.
3. Use a Caulking Gun to apply Sealant along the bottom of the Ceramic.

Notice:

- When adjusting the product position, make small and gentle movements. Avoid making excessive adjustments.
- After applying the sealant, please wait 48 hours before using the product.

四. 安装遥控器 Remote Control Installation

安装前注意事项

- 如果墙壁由特殊材料制成（如木板或密制板），请使用适当的安装方法。
- 请勿将遥控器安装在可能进水的地方。
- 为遥控器支架选择一个着座时容易触及的位置。
- 确保产品周围没有障碍物。

Precautions before Installation

- If the wall is made of a special material (such as wood or plywood), use an appropriate mounting method.
- Do not install the remote control in a location where it could be exposed to water.
- Choose a location for the remote control bracket so that is easy reach when sitting on the toilet.
- Make sure there are no obstacles around the product.

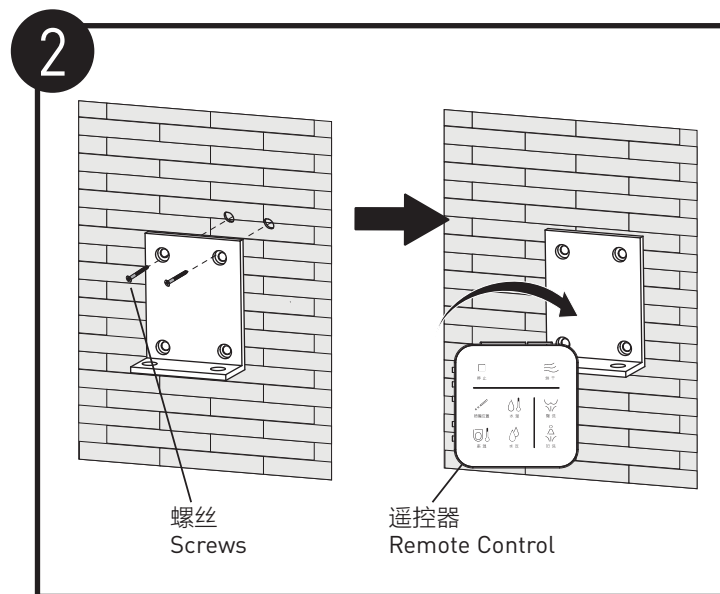
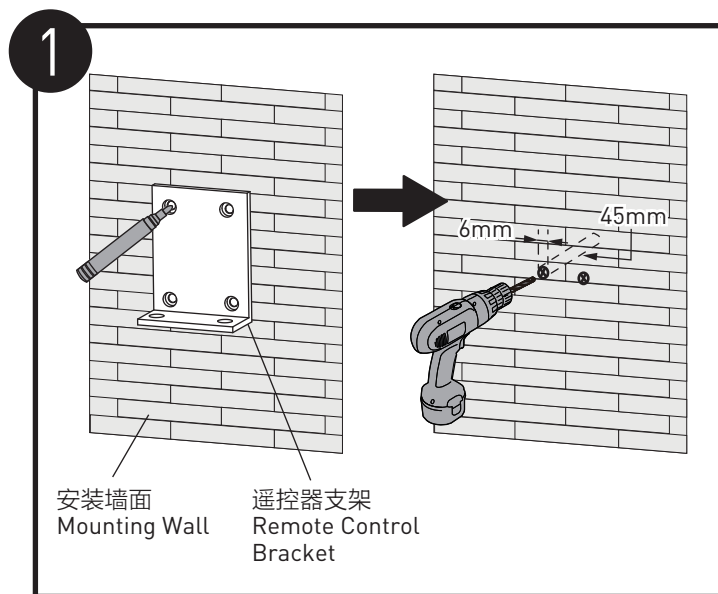

警告 WARNING

本产品必须可靠接地。
否则可能会因故障或短路而导致触电。
当不确定时，请联系电器安装公司。



The product should be electrically grounded appropriately.
Not doing so may cause electric shock due to malfunction or short circuit,
Contact local power supplier, if the power supply is not installed properly.

请勿用湿手触摸或插拔电源插头。
否则有触电的危险。



Do not touch or plug the power plug with wet hands.
Otherwise electric shock may occur.

请勿使用不良的电源插座或破损的电源插头。
否则会导致触电或引发火灾等危险。



Do not use a faulty power socket or a damaged power plug.
Otherwise, it may cause electric shock or fire.

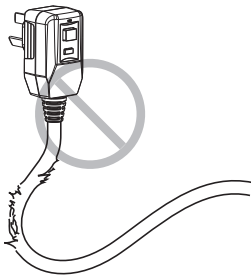

请使用符合规格的电源插座
(额定电压: 交流220V ± 10%, 额定电流: ≥ 10A)。
否则容易引发火灾、触电。



Please use a socket that meets the specifications
(Rated voltage: AC 220V±10%, Rated current: ≥10A).
Use of the power supply other than the above scope would cause electric shock or fire hazard.

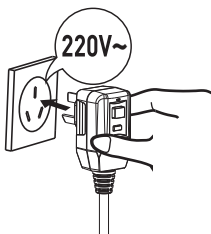

请勿将点燃的香烟及其他燃烧物投入坐便器内。
否则容易发生火灾。



Do not throw the lit cigarettes or other burning things into the toilet.
Otherwise fire hazard may occur.

请勿在雷电天气下使用(在附近发生雷电时, 请拔下电源插头)。
否则可能会引发事故或发生故障。



Do not use during the thunderstorms (When there has thunderstorms nearby, please unplug the toilet)
Otherwise accidents or toilet malfunction may occur.

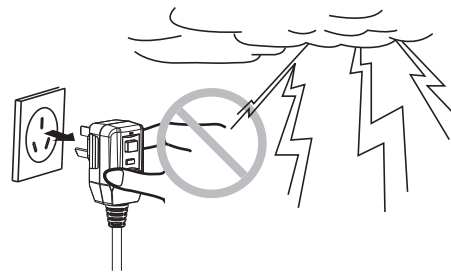

座圈与盖板发生损坏时, 为了避免危险请您务必拔掉电源插头、关闭水源, 并请联系当地经销商进行更换。
否则容易发生触电、火灾的危险。



When the lid or seat plate damaged, unplug the toilet, close the water shutoff valve, and contact the local AD to replace.
Otherwise electric shock or fire hazard may occur.

请定期将电源插头拔下, 用干布擦拭电源插头上的灰尘。



否则当绝缘不良时, 会引发火灾。

Unplug the power plug regularly, wipe away the dust with a piece of dry cloth.

Negligence in dust clean would cause short cut which leads fire hazard.

身体、感知、智力能力缺陷或经验和常识缺乏的人(包括儿童), 请在有人陪同下使用。
否则长时间使用, 有可能造成低温灼伤。



A close supervision is required for children, elderly, patients, retarded and disabled people to use this toilet.
Long using may cause low temperature burn.

请勿将小便射进暖风出口位置。

否则会有触电的危险。

Do not urinate into the heater outlet

Otherwise, it is easy to cause electric shock.



- 严禁在高温环境下使用或放置遥控器，例如火源、加热器附近等，否则可能导致电池过热、起火，或使功能失效、寿命缩短。
- 严禁将遥控器浸入水中。
- 严禁敲击、抛掷、踩踏、坠落、拆解、冲击遥控器。
- 严禁在强静电和强磁场的地方使用遥控器。
- 遥控器内含强磁铁，体内装有心脏起搏器或其他辅助医疗设备的用户请勿近距离使用。
- Do not use or place the remote control in high-temperature environments, such as near a fire or heater, as this may cause the battery to overheat, catch fire, or result in malfunction and reduced lifespan.
- It is strictly forbidden to immerse the remote control in water.
- It is strictly forbidden to knock, throw, step on, drop, disassemble or impact the remote Control.
- It is strictly forbidden to use the remote Control in places with strong static electricity or strong magnetic fields.
- The remote control contains a strong magnet. Users with implanted cardiac pacemakers or other medical devices should not use it at close range.



请按以下方法正确使用遥控器。

- 由于电池能量耗尽会影响信号的接收，请及时充电。
- 充电时请选用输出不能超过500mA电流的适配器。
- 如果遥控器发出异味、发热、变形或使用、贮存、充电过程中出现任何异常，立即停止充电或停止使用，将其安全隔离并移交给原厂维修或更换（超过保修期直接报废处理）。



Please use the remote Control correctly as follows.

- As the battery energy depletion will affect the signal reception, please charge it in time.
- When charging, please use an adapter with an output of no more than 500mA.
- If odor, heat, deformation or any abnormality occurs with the remote Control during use, storage or charging, immediately stop charging or stop using it, isolate it safely and hand it over to the original factory for repair or replacement (dispose of it by scrapping it directly upon expiry of the warranty period).

二. 遥控器的使用说明 Remote Control Use Instructions

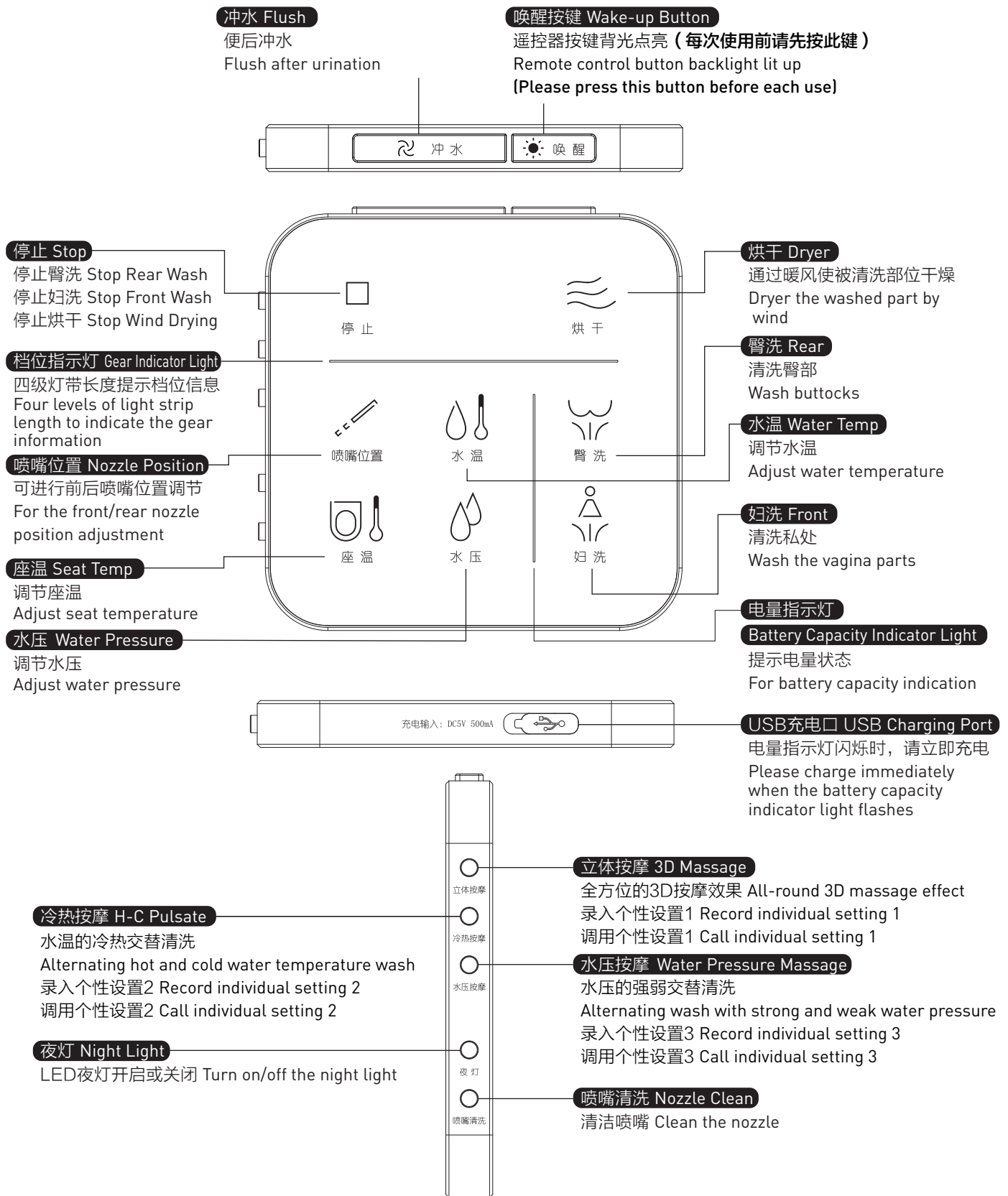

遥控器对码

如果用户装有两台或以上同品牌智能坐便器，使用遥控器时可能会有相互影响的现象，此时使用遥控器对码功能，保证遥控器和产品的唯一性。执行对码操作时，必须将附近其他智能坐便器的电源插头拔掉。

1. 拔下产品插头，长按唤醒按键3s直至档位指示灯闪烁后松开。
2. 将遥控器靠近产品后插上插头。
3. 档位灯停止闪烁后常亮。
4. 此时对码成功。

三. 功能使用说明 Basic Use Function

座温 (座圈加热/座温调节) Seat Temp

[Seat Heating/Seat Temperature Adjustment]

按下“座温”按键调节座温。

第一次按动按键时，显示当前温度档位。再次按动按键，则为切换温度档位，即可设定为适宜的温度。

Press the **Seat Temp** button to adjust the seat temperature.

When the button is pressed for the first time, the current temperature gear is displayed. When the button is pressed again, the temperature gear can be switched and be set to the appropriate temperature.

水压 Water Pressure

按下“水压”按键调节清洗水压。

第一次按动按键时，显示当前水压档位。再次按动按键，则为切换水压档位，即可设定为适宜的水压。可进行4档水压调节。

Press the **Water Pressure** button to adjust the water pressure for wash.

When the button is pressed for the first time, the current water pressure gear is displayed. When the button is pressed again, the water pressure gear can be switched and be set to the appropriate water pressure.

4 levels of water pressure can be adjusted.

Remote Control Code Pairing

If you have more than two items of the same brand smart toilet, there maybe interaction while using remote control. In this condition, use the code pairing function to pair the remote control and the toilet. During match operation, you must unplug the power of other smart toilets nearby.

1. Unplug the product plug, press and hold the **Stop** button until the gear light flashes.
2. Place the remote control close to the product and plug it in.
3. The gear light stops flashing and then lights up normally.
4. At this time, the code pairing is successful.

臀洗 Rear

按下“臀洗”按键。清洗水流从喷嘴的前端喷出，以往复清洗的方式清洗臀部。再次按下“臀洗”按键，喷枪停止往复运动，以固定位置清洗臀部。

※在臀洗时，连续按遥控器上的“臀洗”按键5下，实现开启/关闭宽幅清洗功能。

Press the **Rear** button.

The wash water is sprayed from the front of the nozzle to wash the buttocks in a moving manner. Press the **Rear** button again, the nozzle stops moving and washes the buttocks in a fixed position.

※Press the **Rear** button on the remote control 5 times in succession to turn on/off the wide range wash function during the rear wash.

妇洗 Front

按下“妇洗”按键。清洗水流从喷嘴的前端喷出，以往复清洗的方式清洗女性私密处。再次按下“妇洗”按键，喷枪停止往复运动，以固定位置清洗女性私密处。

※在妇洗时，连续按遥控器上的“妇洗”按键5下，实现开启/关闭宽幅清洗功能。

Press the **Front** button.

The wash water is sprayed from the front of the nozzle to wash the lady parts in a moving manner. Press the **Front** button again, the nozzle stops moving and washes the lady parts in a fixed position.

※Press the **Front** button on the remote control 5 times in succession to turn on/off the wide range wash function during the front wash.

注意:

- 水压低时，清洗强度弱，有时喷嘴不出水。此时，请提高清洗强度。
- 请靠里坐在座圈上，这样飞溅水量将减少。

Notice:

- When the water pressure is low, the wash strength is weak, and sometimes the nozzle does not spray water. In this case, please increase the wash strength.
- Please sit towards the inner side of the seat so that the splashing water will be reduced.

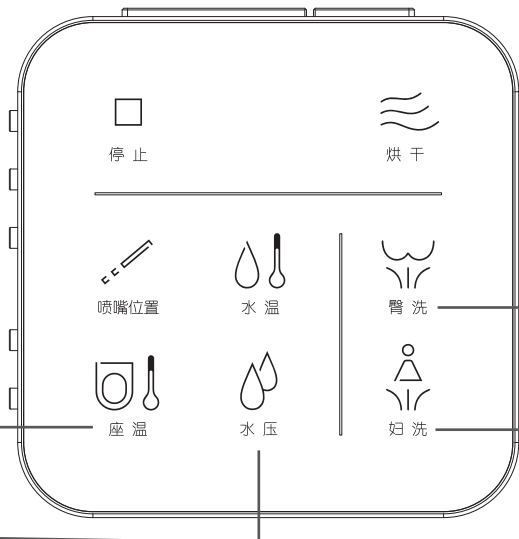

停止 Stop

按下“停止”按键停止臀洗、妇洗、烘干功能。
 ※臀洗和妇洗，具有4分钟后自动停止功能。
 Press the **Stop** button. Stop the functions of Rear Wash, Front Wash, and Wind Drying.
 ※The rear wash and front wash can be stopped automatically after 4 minutes.

烘干（暖风烘干/快速烘干）

Dryer (Wind Drying/Flash Drying)

按下“烘干”按键，对清洗过的部位烘干。
 ●功能运行时，短按“烘干”按键进行风温调节。
 ●功能运行时，长按“烘干”按键进行风速调节。
 ※烘干具有4分钟后自动停止功能。
 Press the **Dryer** button to dry the cleaned parts.
 When the function is active, short press the **Dryer** button to adjust the wind temperature.
 When the function is active, press and hold the **Dryer** button to adjust the wind speed temperature.
 ※The drying can be stopped automatically after 4 minutes.

水温 Water Temp

按下“水温”按键进行清洗水温调节。
 第一次按动按键时，显示当前温度档位。再次按动按键，则为切换温度档位，即可设定为适宜的温度。
 Press the **Water Temp** button to adjust the water temperature for wash.
 When the button is pressed for the first time, the current temperature gear is displayed. When the button is pressed again, the temperature gear can be switched and be set to the appropriate temperature.

电量指示灯 Battery Capacity Indicator Light

提示遥控器电量。
 低电量时，此区域指示灯闪烁；
 充电时，此区域指示灯闪烁；
 充满电时，此区域指示灯常亮。
 It is used to indicate the battery capacity of the remote control.
 The indicator light in this area flashes when the battery capacity is low;
 The indicator light in this area flashes when the battery is charging;
 The indicator light in this area is normally on when the battery is fully charged.

喷嘴位置 Nozzle Position

按下“喷嘴位置”按键进行前后4档喷嘴位置调节。
 Press the **Nozzle Position** button to adjust the nozzle position for 4 position.

	灯带状态 Light Strip State	座温 Seat Temp	水温 Water Temp	风温 Wind Temp	喷嘴位置 Nozzle Position	水压 Water Pressure
指示灯带 Indicator Light Strip	亮1节灯 One Light On	关档 OFF	关档 OFF	关档 OFF	1档 Gear 1	1档 Gear 1
	亮2节灯 Two Light On	34℃	34℃	35℃	2档 Gear 2	2档 Gear 2
	亮3节灯 Three Light On	37℃	37℃	45℃	3档 Gear 3	3档 Gear 3
	亮4节灯 Four Light On	39℃	39℃	55℃	4档 Gear 4	4档 Gear 4

※以上温度仅为参考值。

水温档位提示音：关档（鸣一声）、低档（鸣一声）、中档（鸣一声）、高档（鸣一声）。

风温档位提示音：关档（鸣一声）、低档（鸣一声）、中档（鸣一声）、高档（鸣一声）。

座温档位提示音：关档（鸣一声）、低档（鸣一声）、中档（鸣一声）、高档（鸣一声）。

※ The above temperature values are only for reference.

Water temperature range prompt sound: Off(Sound a voice), Low gear(Sound a voice), Medium gear(Sound a voice), and High gear(Sound a voice).

Wind temperature range prompt sound: Off(Sound a voice), Low gear(Sound a voice), Medium gear(Sound a voice), and High gear(Sound a voice).

Seat temperature range prompt sound: Off(Sound a voice), Low gear(Sound a voice), Medium gear(Sound a voice), and High gear(Sound a voice).

冷热按摩 H-Cold Pulsate

按下“冷热按摩”按键，冷热按摩功能开启或关闭。在臀洗、妇洗、智能臀洗和智能妇洗模式下，按冷热按摩按键来实现水温的冷热交替清洗。
※该功能只能在清洗模式下才能使用

Press the **H-C Pulsate** button to turn on or off the hot and cold massage function.
In the modes of **Rear, Front, Smart Rear Wash, and Smart Front Wash**, press the **H-C Pulsate** button to achieve alternate hot and cold water temperature wash.
※This function can only be activated in the wash mode.

水压按摩 Water Pressure Massage

按下“水压按摩”按键，水压按摩功能开启或关闭。在臀洗、妇洗、智能臀洗和智能妇洗模式下，按水压按摩按键来实现水压的强弱交替清洗。
※该功能只能在清洗模式下才能使用。

Press the **Water Pressure Massage** button, the water pressure massage function is enabled.
In the modes of **Rear, Front, Smart Rear Wash, and Smart Front Wash**, press the **Water Pressure Massage** button to enable alternating wash with strong and weak water pressure.
※This function can only be activated in the wash mode.

智能夜灯 Smart Night Lights

长按“夜灯”按键3秒以上，关闭或开启智能夜灯模式。
●智能夜灯功能开启时，夜灯可随环境光线自动打开或关闭。

●智能夜灯功能关闭时，短按“夜灯”按键，夜灯关闭；再次短按“夜灯”按键，夜灯打开，可反复切换。
※出厂设置智能夜灯功能为开启状态。

Press and hold the **Night Light** button for more than 3 seconds to turn on/off the intelligent night light mode.

●The night light is designed to automatically turn on/off as the ambient light changes when the intelligent night light mode is on.

●Short press the **Night Light** button to turn off the night light when the intelligent night light mode is off; by pressing the **Night Light** button again, the night light can be turned on.

※The intelligent night light mode is defaulted as ON before delivery.

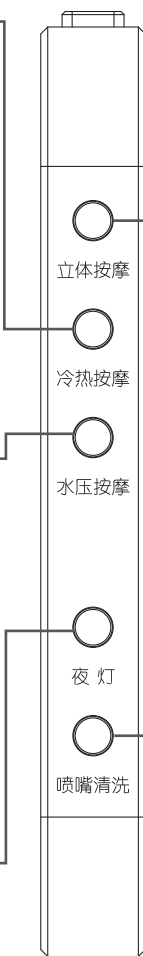

立体按摩 3D Massage

按下“立体按摩”按键，立体按摩功能开启或关闭。在臀洗、妇洗、智能臀洗和智能妇洗模式下，按立体按摩按键实现水柱的前后来回清洗、水压的强弱交替清洗、水温的冷热交替清洗同时进行，达到立体按摩效果。
※该功能只能在清洗模式下才能使用。
※立体按摩包含了水压按摩和冷热按摩，所以在立体按摩下上述按键无效。

Press the **3D Massage** button to turn on or off the 3D massage function.
In the modes of rear wash, front wash, smart rear wash, and smart front wash, press the **3D Massage** button to enable forward and backward moving wash with water column, alternating wash with strong and weak water pressure, and alternating wash with hot and cold water temperature. These wash modes run simultaneously to achieve the effect of 3D massage.
※This function can only be activated in the wash mode.
※The 3D massage contains water pressure massage and hot and cold water massage, so the above buttons are invalid in the 3D massage mode.

喷嘴清洗 Nozzle Clean

按下“喷嘴清洗”按键。清洗器伸出供手工清洁清洗器时使用。
※该功能只能在人体或其它物品未接触座圈感应区域下使用。

Press the **Nozzle Clean** button.
The washer extends for manual cleaning.
※This function can only be activated when the human body or other objects are not in contact with the seat sensor area.

个性设置 Individual Setting

- 1.个性设置功能录入方法：任意座圈感应状态下，用户通过清洗功能调节出适合自己的水温、座温、风温、水压、喷嘴位置后，长按【立体按摩】（个性设置1）、【冷热按摩】（个性设置2）、【水压按摩】（个性设置3）对应键3秒，听到提示音后，录入成功。
 - 2.个性设置功能调用方法：任意座圈感应状态下，连接2下【立体按摩】（个性设置1）、【冷热按摩】（个性设置2）、【水压按摩】（个性设置3）对应键，听到提示音后，调用成功。
1. The method to record individual setting: in arbitrarily states of seat-sensor, after adjusting the water temperature, seat temperature, air temperature, water pressure and nozzle position, long press the corresponding keys such as [3D Massage] (individual setting 1), [Hot and Cold Massage] (individual setting 2) and [Water Pressure Massage] (individual setting 3) for 3 seconds, after hearing the beep, record successfully.
2. The method to call individual setting: in arbitrarily states of seat-sensor, double-click the corresponding keys such as [3D Massage] (individual setting 1), [Hot and Cold Massage] (individual setting 2) and [Water Pressure Massage] (individual setting 3), after hearing the beep, call successfully.

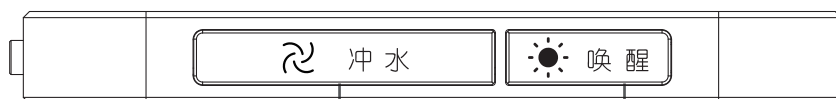

冲水 Flush

按下“冲水”按键。进行遥控冲水一次。
Press the **Flush** button.
Remote control flushing is performed once.

唤醒 Wake-up

按下“唤醒”按键。遥控器按键背光点亮。
Press the **Wake-up** button.
The remote control button backlight will light up.

电源/停止 Powered-On/Stop

待机时：长按旋钮3秒开机。

开机且未着座时：长按旋钮3秒进入待机模式。

着座且无功能运行时：长按旋钮3秒开启烘干功能。

开机且着座时：臀洗、妇洗、烘干情况下短按旋钮停止。

Standby mode: Press and hold the knob for 3 seconds to power on.

Powered on and not seated: Press and hold the knob for 3 seconds to enter the standby mode.

When seating and running without function: press and hold the knob for 3 seconds to realize the wind drying function.

Powered on and seated: When the **Rear Wash**, **Front Wash**, or **Dryer** is running, short press the knob to stop.

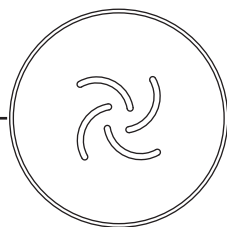

冲水 Flush

着座且无功能运行时或离座时。

短按旋钮中间键发送冲水命令，实现冲水一次。

Seated with no functions running, or not seated.

Short press the middle button of the knob to send the flush command, so as to realize flush once.

※冲洗一次后须等水箱蓄到足够水后才能进行下一次冲水，蓄水时间约为30秒。

※After flushed once, it need take 30 seconds to store water before next flushing.

智能臀洗（一键清洗） Smart Rear Wash (One-Touch Wash)

开机时，着座且无清洗、烘干状态下。

逆时针旋转45°以上发送智能臀洗命令。进入智能臀洗状态，清洗默认为往复清洗开启状态，整个功能运行周期为：臀洗1.5分钟+暖风烘干4分钟+暖风烘干时冲水一次。

在智能臀洗状态下，长按旋钮中间键3秒可切换暖风烘干功能；顺时针旋转增加清洗强度，逆时针旋转减少清洗强度。

When it is powered on, seated without washing or drying. Counterclockwise the knob for 45° or more to send Smart Rear Wash command. Smart Rear Wash is activated, and the Move Wash mode is enabled by default. The entire functional operating cycle is: Rear Wash for 1.5 minutes + wind drying for 4 minutes + flush once during wind drying.

In the Smart Rear Wash mode, press and hold the middle button of the knob for 3 seconds to switch to the Wind Drying function. Clockwise the knob once again to increase the wash strength, and counterclockwise the knob to reduce the wash strength.

智能妇洗（一键清洗） Smart Front Wash (One-Touch Wash)

开机时，着座且无清洗、烘干状态下。

顺时针旋转45°以上发送智能妇洗命令，进入智能妇洗状态，清洗默认为往复清洗开启状态，整个功能运行周期为：妇洗1.5分钟+暖风烘干4分钟+暖风烘干时冲水一次。

在智能妇洗状态下，长按旋钮中间键3秒可切换暖风烘干功能；顺时针旋转增加清洗强度，逆时针旋转减少清洗强度。

When it is powered on, seated without washing or drying. Clockwise the knob for 45° or more to send Smart Front Wash command, Smart Front Wash is activated, and the Move Wash mode is enabled by default. The entire functional operating cycle is: Front Wash for 1.5 minutes + Wind Drying for 4 minutes + flush once during Wind Drying.

In the Smart Front Wash mode, press and hold the middle button of the knob for 3 seconds to switch to the Wind Drying function. Clockwise the knob once again to increase the wash strength, and counterclockwise the knob to reduce the wash strength.

脚触功能 Foot-Touch Function

轻触“脚触按钮”。

- 关圈关盖时：脚触第一次实现开盖，脚触第二次实现开圈，脚触第三次实现关圈关盖+冲水。
- 关圈开盖时：离座状态下，脚触实现开圈。
- 开圈开盖时：脚触关圈关盖+冲水。
- 着座时：人体落座后，脚触无反应。

注意：

- 请勿用力或频繁操作此脚触按钮。
- 产品在自动运转时，请勿用力强行阻止或反向转动，否则易损坏内部精密零件。
- 请勿用力或快速打开关闭座盖/圈，否则易损坏内部精密零件。

脚触冲水 Foot-Touch Flush

当座盖座圈打开状态下，轻触“脚触按钮”先关闭座圈和座盖，再启动冲水。

男士小便冲水 Flush for Male Urination

在感应微波和手势微波状态下，当座圈打开的状态，感应到人离开，自动关圈关盖后冲水一次。

离座冲水 Automatic Flush

当人体着座后离座会自动进行一次冲水。

注意：待机状态下，按住旋钮中间键逆时针旋转，开启或关闭离座冲水功能。

烘干冲水 Wind Drying with Flush

清洗后且未进行冲水，按下“烘干”按键。暖风烘干功能启动并进行一次冲水。

停电冲水 Emergency Flush

产品不插电源时，短按旋钮中间键，实现停电冲水功能。

注意：以上操作无效时，需要更换电池或联系当地经销商。

Slightly touch the "Foot-Touch" button.

- Seat closed, lid closed: Three foot-touch operations can be performed, i.e., the first time to open the lid, the second time to open the seat, and the third time to close the lid and seat and flush.
- Seat closed, lid open: The Foot-Touch operation will open the seat.
- Seat open, lid open: The Foot-Touch operation will close the lid and seat and flush.
- When seated: After the human body is seated, the Foot-Touch function will be disabled.

Notice:

- Do not use excessive force or press the Foot-Touch button frequently.
- When the product is running automatically, do not forcefully stop or reverse the rotation, otherwise, it may damage the internal precision parts.
- Do not force or quickly open or close the lid and the seat, otherwise it may damage the internal precision parts.

When both the lid and seat are open, gently touch the "Foot-Touch" button will cause the toilet to close the seat and lid in sequence, followed by a flush.

In the state of microwave & gesture microwave mode with seat opened, it can auto-close the lid and seat, flush in one time after sensing users leave.

When the human body leaves the seat after seating, it will automatically flush once.

Notice: In the standby mode, press and hold the middle button of the knob and counterclockwise the knob to turn on or off the automatic flushing function.

After operating the rear wash or front wash function on the remote control, press the **Dryer** button. The wind drying function will be activated and flush once.

When the product is not powered on, short press the middle button of the knob to realize the function of flushing in case of power failure.

Notice: If the above operation does not work, replace battery or contact the local dealer.

Notice: During flushing, **Rear Wash**, **Front Wash**, and other functions are disabled.

注意：在冲水过程中，臀洗、妇洗等功能是不可以使用的。

语音控制 Voice Control

对智能坐便器说“小摩小摩”等语音词条进行唤醒，唤醒后按相应词条对智能坐便器进行操作。

以下中文语音词条可以语音唤醒，英文语音词条无法语音唤醒。

Wake up the smart toilet by voice entries such as "Xiaomo Xiaomo", then operate on smart toilet according to the corresponding entries.

The smart toilet can only be waked up by Chinese voice entries as follows, instead of the English voice entries.

语音词条 Voice Entries	智能坐便器执行的动作 Perform Actions By Toilet
小摩小摩、小智小智、小月小月、小新小新	语音唤醒 Voice Wake Up
暂停、停止	停止 Stop
臀部清洗、打开臀洗、开始臀洗、臀洗打开、开臀洗、臀洗开、臀洗开始、后洗净	打开臀洗 Open Rear
暂停、停止、清洗停止、停止清洗	关闭臀洗 Close Rear
女性清洗、开妇洗、打开妇洗、开始妇洗、妇洗开始、妇洗打开、前洗净	打开妇洗 Open Front
暂停、停止、清洗停止、停止清洗	关闭妇洗 Close Front
开烘干、打开烘干、开始烘干、烘干开、烘干打开、烘干开始	打开烘干 Open Wind Dryer
停止烘干、烘干停止、关闭烘干、烘干关闭	关闭烘干 Close Wind Dryer
开盖子、打开盖子、开座盖、开马桶盖、打开马桶盖、盖子打开、座盖开、座盖打开、马桶盖打开、打开座盖	打开座盖 Open Lid
关盖子、关上盖子、关座盖、关上座盖、关马桶盖、关闭马桶盖、关上马桶盖、盖子关上、座盖关闭、马桶盖关闭、马桶盖关上、关闭座盖	关闭座盖 Close Lid
开座圈、开启座圈、座圈开、座圈打开、座圈开启、打开座圈	打开座圈 Open Seat
关座圈、关上座圈、座圈关上、关闭座圈	关闭座圈 Close Seat
冲马桶、开始冲水、马桶冲水	冲水 Flush
打开播报、打开语音反馈	开启语音 Open Voice Control
关闭播报、关闭语音反馈	关闭语音 Close Voice Control
音量加、增加音量	增加音量 Increase The Volume
音量减、降低音量	降低音量 Turn Down The Volume

温馨提示:

1. 请使用标准普通话。
2. 使用环境噪音过大，可能会造成语音接收不灵敏或误动作。

Tips:

1. Please speak Mandarin.
2. Ambient noise is too loud may cause insensitive voice reception or incorrect actions.

更多人性化贴心设计 More Humanized and Thoughtful Design

- **喷嘴自洁**
清洗器自动清洁，细菌污渍统统远离。
- **座圈/座盖缓降**
产品增加阻尼功能，使座圈/座盖平稳起落，从而起到良好的静音效果。
- **即热恒温**
采用先进的即热式技术，真正的极速体验。
- **来电自启**
通电后，机器直接开机。
- **预润净瓷**
着座后，刷圈冲水一次，确保圈壁润湿。
- **前置过滤**
配备专用的PP棉前置过滤器和钢网过滤器净化水源，保证用户清洗时的干净卫生。
- **空气隔离/防止逆流**
采用专利技术，用空气隔离水路，防止污水逆流对生活用水构成污染，绝对保证用户家庭生活用水安全。
- **低压冲洗**
在低水压状态下，可以进行陶瓷冲水功能。
- **易洁釉面**
超平滑表面，给您莲叶般的易洁效果，让冲洗更简单。
- **抗菌喷枪/抗菌座圈**
喷枪/座圈使用抗菌材料。
- **智能节电**
当人体着座时，座圈温度自动降低，节能环保且防止灼伤。
- **安全保护**
本产品特有漏电保护等八重保护措施，确保用户的安全使用。
- **休眠模式**
若24小时内无任何使用或操作，智能马桶将自动进入休眠模式。一旦有操作发生，系统将立即恢复之前的设置状态。
- **Nozzle Self Cleaning**
The washer can automatically clean, keeping bacteria and stains away.
- **Soft-Close Seat/Lid**
The product has a damping function to make the seat/lid rise and fall smoothly, thus playing a good silent effect.
- **Instant Heating**
With advanced instant heating technology, a truly speedy heating experience is achieved.
- **Auto-start**
The product will turn on directly after the power is on.
- **Pre-flush**
After seating, the product will flush once towards the seat to ensure that the seat wall is moistened.
- **Pre-filter**
It is equipped with dedicated PP cotton pre-filter and steel mesh filter to purify the water supply to ensure a hygienic cleaning for users.
- **Air Isolation/Anti-counterflow**
With the patented technology, it can isolate the water piping with air to prevent the counterflow of sewage from polluting the domestic water, which absolutely ensures the safety of domestic water for users.
- **Low-Pressure Flush**
The ceramic flushing function can be performed in a low water pressure state.
- **Easy-Clean Glaze**
Super smooth surface for easy cleaning like a lotus leaf, making flushing easier.
- **Antibacterial Nozzle/Antibacterial Seat**
Antibacterial material is used for the nozzle and seat.
- **Smart Energy Saving**
Once the user is seated, the seat temperature will be lowered automatically, achieving energy-saving and burn prevention.
- **Safety Protection**
This product has eight protection measures, such as leakage protection, to ensure the safety of users.
- **Automatic Power Off**
The smart toilet automatically enters Automatic Power Off after 24 hours of inactivity. It will instantly revert to its previous settings as soon as any operation is detected.

清洁保养和更换方法 Cleaning, Maintenance and Replacement

为了保证产品的正常使用，请定期对产品进行清洗保养。

注意：

- 在保养前请切断电源，关闭供水角阀，停止供水。
- 保养过程中严禁用水冲洗本产品。

一. 塑料、陶瓷以及金属部件的清洁保养

- 当塑料部件附着灰尘或污垢时，请用柔软的湿布擦拭产品。
- 陶瓷部分可用柔软的刷子、抹布或海绵，以中性清洁剂加凉水或温水进行清洗。
- 金属部分（如转臂、喷嘴等）附着灰尘或污渍时，可用温水擦拭，如有必要可使用中性清洁剂加水擦拭，清洗完成后请用清水冲洗干净，否则易引起表面腐蚀

注意：请勿使用不适合的清洁剂（如浓硫酸、浓硝酸、冰醋酸、四氯化碳、氯仿、丙酮、丁酮、苯、甲苯、苯酚、甲酚、二甲基甲酰胺、甲醚、大豆油、醋酸盐、40%硝酸、浓盐酸、95%酒精、汽油、煤油、刹车油等）。

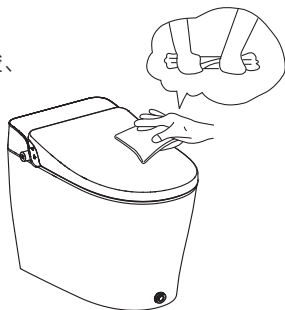

二. 喷嘴的清洁保养方法

- 在开机离座状态，短按“喷嘴清洗”按键，清洗器自动伸出。可一手轻轻托住钢管，一手将喷嘴前端向外拔出。如果喷嘴有污垢，请用牙刷等进行清洁，清洗完毕后，将喷嘴前端插入钢管即可。
- 当喷嘴堵塞时，建议更换新喷嘴。

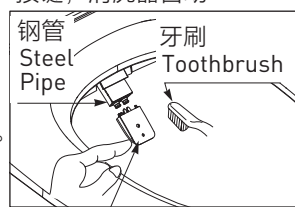

注意：切勿用力过猛，否则会损坏喷嘴。

喷嘴前端
Front End of the Nozzle

三. 前置过滤器的保养

- 前置过滤器应安装在供水角阀上，且应避免在有异物压迫或有腐蚀性物质的附近安装。
- 前置过滤器的安装位置应远离过热的热源（如取暖器、浴霸灯等），应在室内安装，避免在烈日暴晒或天冷结冰的场所。
- 请在前置过滤器达到使用寿命后，及时更换，不可再重新使用。
- 若长时间无人在家（例如旅行等），请关闭供水角阀。

Please clean and maintain the product regularly for the normal use of the product.

Notice:

- Before maintenance, please cut off the power supply, close the water supply angle valve, and stop the water supply.
- Do not rinse this product with water during maintenance.

Cleaning and Maintenance for Plastics Ceramics and Metals

- When dust or dirt sticks to plastic parts, wipe the product with a soft, damp cloth.
- The ceramic parts can be cleaned with a soft brush, rag or sponge, with a neutral detergent and cold or warm water.
- When metal parts (such as Rotating Arm, Nozzle, etc.) are covered with dust or stains, wipe them with warm water. If necessary, use a neutral detergent mixed with water to wipe them. After cleaning, rinse them thoroughly with clean water, otherwise surface corrosion may occur.

Notice: Do not use inappropriate cleaning agents such as concentrated sulphuric acid, nitric acid, glacial acetic acid, carbon tetrachloride, chloroform, acetone, butanone, benzene, toluene, phenol, cresol, dimethyl formamide, methyl ether, soybean oil, acetate, 40% nitric acid, concentrated hydrochloric acid, 95% alcohol, gasoline, kerosene, or brake oil.

Cleaning and Maintenance Methods for Nozzle

- Powered on and not seated: Touch the **Nozzle Clean** button on the remote Control while the toilet is powered on and not seated. The washer will automatically extend. Gently hold the steel pipe with one hand and pull out the front end of the nozzle outward with the other hand. If there is dirt in the nozzle orifice, use a toothbrush to clean it. Once cleaned, insert the front end of the nozzle back into the steel pipe.
- When the nozzle is clogged, it is recommended to replace it with a new one.

Notice: To avoid damaging the nozzle, do not brush hard.

Maintenance Method for Pre-filter

- The pre-filter should be installed on the water supply valve, and it should not be in areas where there are foreign objects pressing against it or corrosive substances nearby.
- The installation location of the pre-filter should be far away from overheated sources (such as heaters, bath heaters, etc.), it should be installed indoors, and avoid places where there is strong sunlight or freezing in cold weather.
- Please timely replace the pre-filter when it reaches the end of its service life and do not reuse it again.
- If no one is at home for a long time (such as traveling, etc.), please turn off the water supply valve.

⚠ 警告 WARNING

请勿向坐便器或遥控器内部加水或清洁剂。
请勿用水或清洁剂弄湿坐便器及电源插头。
否则可能会有触电和发生火灾的危险。

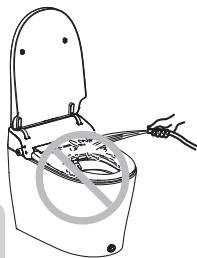

建议每年更换一次滤芯。

滤芯的更换周期会因用户当地的水质及使用过滤水的用量不同而有差异，以上建议更换滤芯的周期仅供参考。

Do not add water or detergent to the toilet or remote control.
Do not wet the toilet and power plug with water or detergent.
There may be a risk of electric shock and fire.

It is recommended to replace the filter element once a year.
The replacement cycle of the filter cartridge may vary depending on the local water quality and the amount of filtered water used by the user. The above recommended replacement cycle for the filter element is for reference only.

四. 角阀过滤网的保养

- 为了您的健康，请根据当地水质情况及时清洗过滤网（或更换过滤网）。
- 当发现清洗强度减弱时，请及时清洗（或更换）过滤网。
在拆卸过滤网前，务必关闭供水角阀。
重新安装过滤网时，请确保拧紧，以防止漏水。

注意：用硬币逆时针旋转打开过滤网。

牙刷 Toothbrush

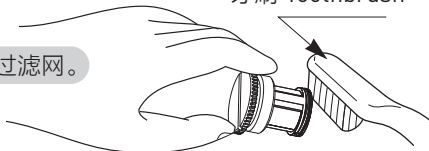

建议1-2个月清洗一次过滤网。

Maintenance Method for Angle Valve Filter

- For your health, please clean the filter screen (or replace the filter screen) according to the local water quality in a timely manner.
- When you notice a decrease in the cleaning intensity, please promptly clean (or replace) the filter screen. Before disassembling the filter screen, make sure to turn off the water supply angle valve. When reinstalling the filter screen, ensure it is tightly fastened to prevent water leaks.

Notice: Open the filter screen by rotating it counterclockwise with a coin.

It is recommended to clean the filter screen once in 1-2 months.

五. 冬季防冻 (环境温度低于4°C时)

1. 当长时间不使用产品时，如出差、外出旅游等，请进行如下操作。
 - a. 先关闭供水角阀，再按一下遥控器上的遥控冲水按键，陶瓷进行两次或以上排水。
 - b. 排水30秒后，请您务必拔掉电源插头。
2. 在寒冷的冬季，当产品在经过长途运输或长时间存放时，产品内剩下的积水可能会发生冻结现象。为预防冻结造成损坏，请采取防冻措施。

注意：

- 在温暖的室内，产品放置30分钟待其自然解冻后再通电。
- 在发生冻结导致无法喷水的情况下，可以将浸过热水的布覆盖在陶瓷冲水系统的供水软管上或供水软管的连接部分，以帮助解冻。请注意不要直接向陶瓷冲水系统的供水软管上浇热水或吹热风。

Winter Anti-freezing Method (Ambient Temperature < 4°C)

1. When not in use for a long period of time, such as on business trips or outings, please do as follows.
 - a. First close the angle valve for water supply, then press the **Flush** button on the remote control. There will be two or more processes of drainage in the ceramic body.
 - b. After draining for 30 seconds, please be sure to unplug the power plug.
2. In the cold winter, when the product is transported over long distances or stored for a long time, the remaining water inside the product may freeze. To prevent damage caused by freezing, please take anti-freezing measures.

Notice:

- In a warm room, leave the product for 30 minutes to thaw naturally before turning on the water supply and power supply.
- In the event of freezing that prevents water from spraying, you can cover the water supply hose of the ceramic flushing system or the connection part of the water supply hose with a cloth soaked in hot water to thaw it. Do not pour hot water on or blow hot air directly onto the water supply hose of the ceramic flushing system.

水效信息 Water Efficiency

水效等级、水效指标请见产品本体上的水效标识。

Please refer to the water efficiency label on the product body for water efficiency grade and water efficiency index.

常见故障诊断 Common Fault Diagnosis

如果发现类似故障，请先阅读以下内容尝试其处置方法来排解故障问题，若仍无法解决问题时，请联系销售单位或拨打客户服务中心电话进行联系。

Please read the following contents and try to solve the fault in other disposal methods if similar faults are found, or contact the sales department or call customer service center if the fault cannot still be solved.

电源开关 Power Switch

故障现象 Failure Phenomenon	故障分析 Failure Analysis	故障处理 Troubleshooting
产品不工作。 Product is not working.	检查是否有电/插座是否松动。 Check if there is electricity / if the socket is loose.	请检查电路。 Check the circuit.
	检查产品电源是否开启（电源指示灯未亮）。 Check whether the power of the product is turned on (the power indicator is off).	长按旋钮3秒，智能坐便器的产品指示灯点亮。 Press and hold the knob for 3 seconds, the product indicator light of the smart toilet will light up.
	是否漏电（漏电保护插头的显示灯未亮）。 Whether the leakage (the indicator light of the leakage protection plug is not on).	从插座上拔下电源插头，稍后再次插入。按下漏电保护插头的复位开关，若还是不能运行时，请拔掉电源插头，委托修理。 Unplug the power plug from the socket and plug it in again later. Press the reset switch of the leakage protection plug. If it still does not work, unplug the power plug and request repairs.

臀洗/妇洗 Rear Wash/Front Wash

故障现象 Failure Phenomenon	故障分析 Failure Analysis	故障处理 Troubleshooting
喷嘴不出水。 No water from the nozzle.	检查是否停水。 Check if there is no water.	待供水恢复。 Wait for water supply to recover.
	检查角阀是否关闭。 Check whether the angle valve is closed.	打开角阀。 Open the angle valve.
	检查进水过滤器是否被堵死。 Check if the water inlet filter is blocked.	清洗过滤网或更换过滤器。 Clean the filter or replace the filter.
	检查进水管是否折弯。 Check if the water inlet pipe is bent.	排除进水管折弯。 Eliminate bending of water inlet pipe.
清洗强度不够。 Insufficient cleaning.	检查清洗水压是否在最低档。 Check whether the cleaning water pressure is at the lowest level.	参照说明书调节水压。 Adjust the water pressure according to the instructions.
	检查进水过滤器是否被堵塞。 Check if the water inlet pipe is bent.	清洗过滤网。 Clean the filter.
喷嘴乱出水。 Water coming out of the nozzle in a messy way.	异常操作。 Abnormal operation.	拔出插头一分钟后重新通电。 Unplug the plug and re-energize it after one minute.
水温不够。 Low water temperature.	检查水温是否在低档。 Check if the water temperature is at a low level.	参照说明书调节水温。 Refer to the instructions to adjust the water temperature.
清洗管常滴水。 Nozzle keeps dripping water.	电磁阀失效。 Solenoid valve failure.	请专业人员维修。 Ask a professional to repair.
清洗功能不能正常使用。 Malfunctioning of the cleaning function.	座圈人体感应失效。 Seat body induction failure.	请专业人员维修。 Ask a professional to repair.

暖风烘干/风温 Warm Air Drying/Wind Temperature

故障现象 Failure Phenomenon	故障分析 Failure Analysis	故障处理 Troubleshooting
烘干吹冷风。 Cold air blowing for drying function.	检查烘干是否设置在关闭档。 Check whether the drying temperature is set at normal temperature.	参照说明书调节暖风。 Adjust the drying temperature according to the instructions.
	烘干加热部件是否损坏。 Whether the drying heating parts are damaged.	请专业人员维修。 Ask a professional to repair.

座温 Seat Temperature

故障现象 Failure Phenomenon	故障分析 Failure Analysis	故障处理 Troubleshooting
座圈温度过低/不加热。 Low seat temperature/ No heating.	检查座圈温度是否设置在关闭档。 Check whether the seat ring temperature is set at normal temperature.	参照说明书调节座温。 Adjust the seat temperature according to the instructions.

遥控器 Remote Control

故障现象 Failure Phenomenon	故障分析 Failure Analysis	故障处理 Troubleshooting
电量指示灯闪烁 Battery capacity indicator light flashes.	电池电量过低 Battery is too low.	请立即充电 Please charge immediately.
遥控器失灵 Malfunctioning of the remote control.	检查遥控器是否进水 Check whether the remote control is soaked.	用干布擦去水滴 Use a dry cloth to remove water drops.

陶瓷 Ceramic Bowl

故障现象 Failure phenomenon	故障分析 Failure analysis	故障处理 Troubleshooting
冲水异常。 Flushing failure.	无供电。 No power supply.	恢复供电。 Power supply restored.
	喷射口不出水。 No water coming out of the nozzle.	请专业人员进行维修。 Ask specialized personnel to repair.
	有冲水运作声无出水。 No water coming out, but with the flushing noise.	1.检查水箱是否进水和进水管路是否通畅。 2.检查水泵是否故障。 1.Check whether the water tank and water inlet pipe is smooth. 2.Check whether the pump is faulty.
	常进水。 Regular water inlet.	检查进水阀是否异常或请专业人员进行维修。 Check whether the water inlet valve is abnormal or ask specialized personnel to repair.

其他 Other

故障现象 Failure Phenomenon	故障分析 Failure Analysis	故障处理 Troubleshooting
座盖/座圈下落过快 Toilet lid/toilet seat falling too fast.	阻尼缓降功能失效 Damping slow down function fails.	请专业人员进行维修 Ask a professional for repair.
脚踏翻盖/翻圈无法开启或关闭 ※仅限于部分型号 Fails to enable or disable the Foot-touch flipping for Lid/Seat. ※This function is limited to some models.	自动阻尼功能故障 Automatic damping function failure.	1.拔出插头一分钟后重新通电 2.上述处理无效, 请专业人员维修 1.Unplug the plug for one minute and then power it on again. 2.If the above method is invalid, please ask the specialized personnel to repair.
各功能有次序的循环工作 Each function works in a sequential cycle.	误进工程调试模式 Engineering commissioning mode enabled by accident.	拔出插头一分钟后重新通电 Unplug the plug for one minute and then power it on again.

技术参数 Technical Specifications

额定电压 Rated Voltage		220V~
额定频率 Rated Frequency		50Hz
额定消耗功率 Rated Power Consumption		入水温度15℃；出水温度39℃；功率1200W Inlet Water Temperature: 15°C, Output Water Temperature: 39°C, Power: 1200W
使用环境温度 Ambient Temperature		4℃-40℃
进水温度 Inlet Water Temperature		4℃-35℃
供水方式 Water Supply Method		DN15 (G1/2)
进水水压范围 Inlet Water Pressure Range	最低必要水压 Minimum Necessary Water Pressure	0.08MPa
	最高水压 Maximum Water Pressure	0.75MPa
坐便器 Toilet	洗净方式 Flushing Method	喷射虹吸式 Siphon Flush
	坑距 Pit Distance	305/400mm
清洗 Cleansing	温水加热方式 Warm Water Heating Method	瞬间加热式 Instant Heating
	温水温度 Warm Water Temperature	关/约34℃-39℃ (4档调节) OFF/About 34°C-39°C (4-Gear Adjustment)
	安全装置 Safety Devices	蝶形温控器、热保护器、流量检测装置 Butterfly-Shaped Thermostat, Thermal Protector, Flow Detection Device
暖风烘干 Warm Air Drying	暖风温度 Warm Air Temperature	关/约35℃-55℃ (4档调节) OFF/About 35°C-55°C (4-Gear Adjustment)
	风速 Wind Speed	大于4m/s > 4m/s
	安全装置 Safety Devices	双金属片温控器、温度保险丝 Bimetal Thermostat, Thermal Cutoff
座圈 Seat	座圈温度 Seat Temperature	关/约34℃-39℃ (4档调节) OFF/About 34°C-39°C (4-Gear Adjustment)
	安全装置 Safety Devices	温度保险丝 Thermal Cutoff
遥控器 Remote Control	尺寸 Dimensions	长122mm×宽122mm×高13.5mm 122mm×122mm×13.5mm (L×W×H)
	电源 Power	DC5V 500mA(充电器自备) DC 5V, 500mA (charger self-provided)
防水等级 Waterproof Level		IPX4
电源线长度 Power Cord Length		约1.5m About 1.5m
产品尺寸 Product Dimensions		684 x 408 x 488mm

※关于额定功率的释义：本产品环境温度 $23^{\circ}\text{C} \pm 2^{\circ}\text{C}$ ，进水静压 $0.2 \pm 0.02\text{MPa}$ ，进水温度 $15^{\circ}\text{C} \pm 0.5^{\circ}\text{C}$ ，额定电压220V~条件下，开始上电开机，依次将清洗强度、座温、水温设置为最高档后，开启清洗并打开移动清洗功能，持续稳定工作一个清洗周期的平均功率。

※Definition of Rated Frequency: when the ambient temperature of the product is $23^{\circ}\text{C} \pm 2^{\circ}\text{C}$, the inlet static pressure is $0.2 \pm 0.02\text{MPa}$, the inlet temperature is $15^{\circ}\text{C} \pm 0.5^{\circ}\text{C}$, and the rated voltage is 220V~, the product starts to power on and start, after the cleaning intensity, seat temperature, and water temperature are set to the highest level, the cleaning is started and the mobile cleaning function is turned on, and the average power of a cleaning cycle is continuously stable.

产品售后保修条款

本产品是在高质量标准及生产工艺下制造的，本公司承诺为消费者购买的产品提供有期限免费保修及终身维修服务。材质为陶瓷的部件免费保修期为5年，非陶瓷材质部件，如智能盖板、智能一体机的盖板组件、水箱内的水件、冲洗阀、坐便器盖板等免费保修期为3年，均自消费者购买日（以本产品分销商开具的发票或收据上载明日期为准）起计。免费保修范围及产品配件（如水箱配件，坐便器盖板等）由于材质及工艺原因而造成的故障或损坏，免费保修期内，我们将无偿为您提供维修服务及更换发生故障的产品或产品配件。本公司的售后服务责任仅限于对故障产品的修理，而不延及您因产品故障而发生的其他损失，法律另有规定的除外。

您需了解：产品外观碰伤、刻划痕迹，以及滥用及不正当保养所导致的故障或损坏，均不属于免费保修范围。即使在免费保修期内，属下列（1）-（5）情况之一的，需酌情收取修理费用：

1. 不能出示相符的保修卡和有效购买凭证情况的；
2. 未按使用说明书告知的使用方法和注意事项造成的故障；
3. 自行拆卸、维修、改装所造成的故障和损坏；
4. 由于不可抗力等外部原因引起的故障和损坏；
5. 由于运输、搬卸、挤压等造成的损坏。

对于保修期外或不在保修范围内的产品，如需维修，本公司将酌情收取上门费、人工费及材料费。

本保修条款仅对原始消费者和酒店行业的购买者有效，并不适用于本产品工业、商业、贸易和非酒店行业的使用。如对本保修条款内容有任何疑问，请拨打 400 630 8866 咨询热线，或向当地分销商咨询。对于中国大陆以外的市场，此产品的保修及保障服务详情请咨询当地经销商。本公司对本产品保修拥有最终解释权。

PRODUCT LIMITED WARRANTY

We offer limited warranty and lifetime maintenance for the products, which are all manufactured with high standards of workmanship.

The free warranty period for ceramic parts is 5 years, non-ceramic parts, such as the smart toilet seat, water fittings, flush valve, toilet cover, etc. is 3 years, both since the consumer's purchase date (based on invoices or receipts issued by the product distributors).

This warranty is your coverage against material and workmanship malfunction or defects in the products or components (water tank accessories, toilet cover, etc.). During the warranty period, we offer free maintenance and changing of malfunctioned products or product components. The company's after sales service liability is limited to the maintenance of faulty items and does not cover your other losses caused by product malfunction, except for otherwise stipulated by law. Cosmetic damages (scratches, dents, etc.) and malfunction or defects caused by abuse or improper maintenance is not covered by this warranty. Although the warranty period remains valid, in case of the following conditions (1) - (5), the maintenance cost (material cost and labor cost) shall still be charged as the case may be:

1. Corresponding warranty card and valid invoice cannot be presented;
2. Faults were caused by the incompliance with the instructions and precautions provided in the user's manual;
3. Damages and faults were caused by self-actuated dismantling, repair and refit;
4. Faults and damages were caused by external factors such as force majeure;
5. Damages were caused by transportation, unloading and extrusion, etc.

This warranty is valid for the original consumers only (including hotel use), and excludes industrial and commercial use of the product (except for hotel use).

This card is only responsible for product maintenance rather than any other liabilities.

In the event that the product requires maintenance but exceeds the warranty period, or that the product is not covered by this warranty, labor cost and material cost shall be charged as the case may be.

Please call 400-630-8866 or contact local dealer for any question. For markets exclude Chinese mainland, the terms and conditions of warranty shall differ between product categories and countries. Please refer to warranty stated by local distribution.

The company Incorporated shall have the final interpretation of the product warranties.

